

DATA SHEET FOR CANTILEVER GATES

Description

Data sheet for the design and installation of traditional cantilever gates

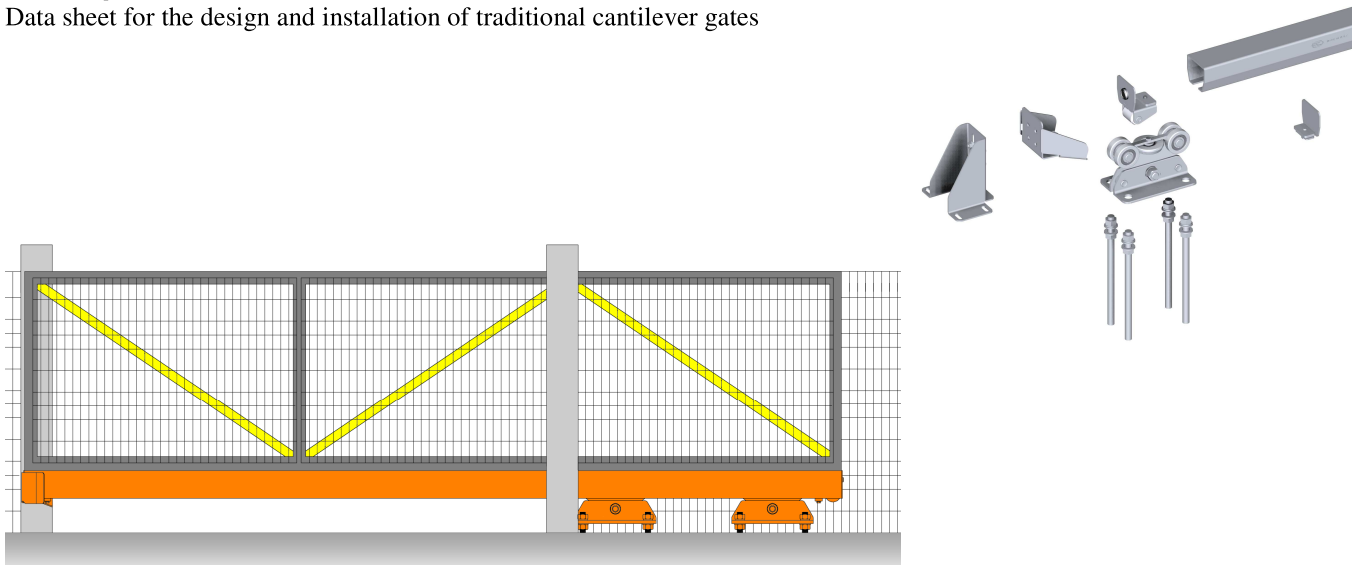

Assembly Sequence

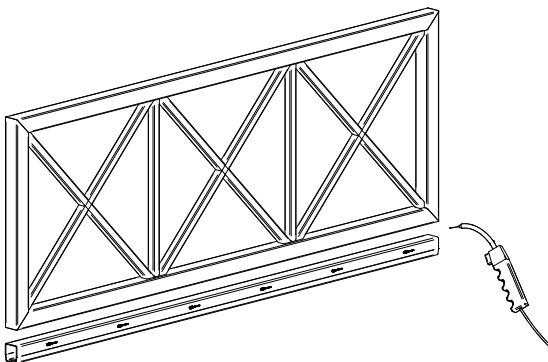

- 1) Prepare a Guide of length S and weld under the gate.

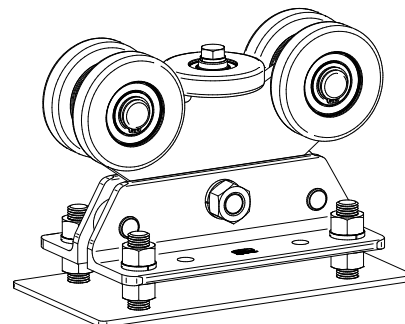

- 2) Fix the trolleys to the ground using the fixing rods, the weight of the cement block under the trolley must be greater than the given Z_{min} value.

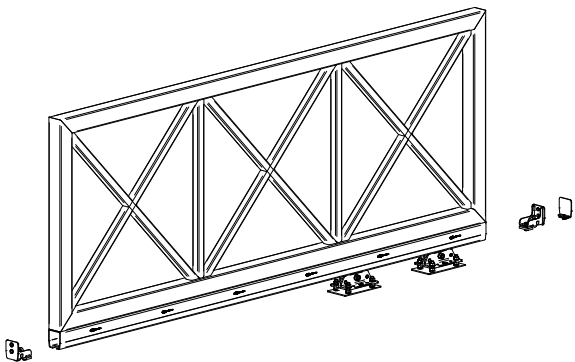

- 3) Slide the gate guide over the trolleys and fix the Guide Roller on one end and a Guide Roller and/or the Front Cover on the other end.

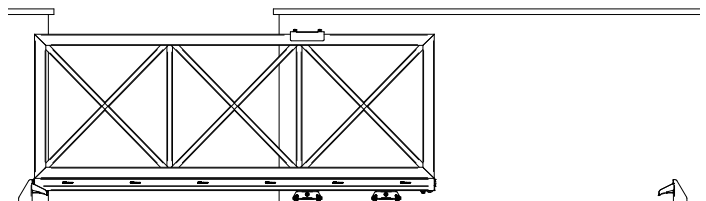

- 4) Adjust the height and the pitch of the gate by acting on the nuts and bolts and lock the upper guide plates and the limit stop.

How to select the right series for you

Once calculated the A/C ratio of the gate, find the point on the graph (see here below) that corresponds to the gate weight. The parts to be used are those whose curve is above this point. If the gate does not have the weight distributed evenly use the second graph. The dotted lines refer to load conditions acceptable in terms of safety, but are not ideal in terms of durability and functionality. For heavy duty applications it is best to refer to the solid lines found within the given graph. Always keep in mind the following information:

- For P you have to consider the total weight of the gate, including the weight of all accessories.
- A low A/C ratio translates into a better gate performance. A low ratio reduces the forces involved, flexion, rocking and wobbling effects.
- It is recommended to have an A/C ratio below 3, in any case the value should always be between 1 and 4 and never exceeding the 4 value.
- Should you choose the 3000 Series, we recommended to keep the higher wheels towards the outside.
- To calculate the size and the loads acting on the gate, FAC provides a spreadsheet in Excel that does all the calculations for each specific condition. For more information contact FAC or visit www.facsrl.com

Uniform load

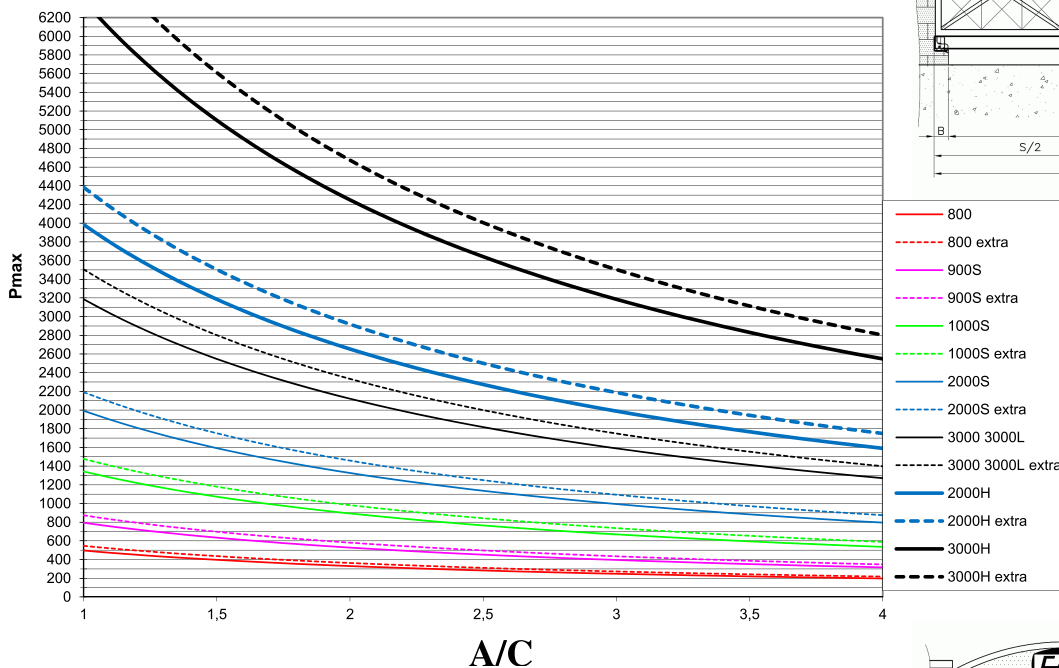

Uneven load

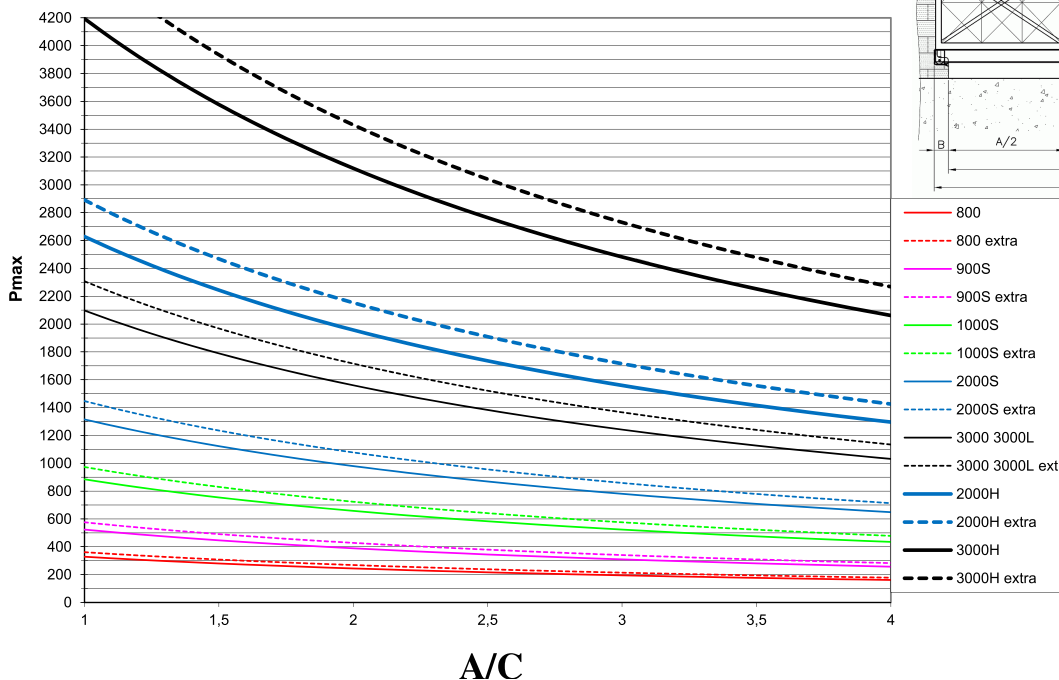

Attention: installations that do not comply with the illustrated procedure or failure to carry out correct maintenance operations can cause the gate to derail and endanger the safety of persons and property

DIMENTIONING EXAMPLES PER SERIES

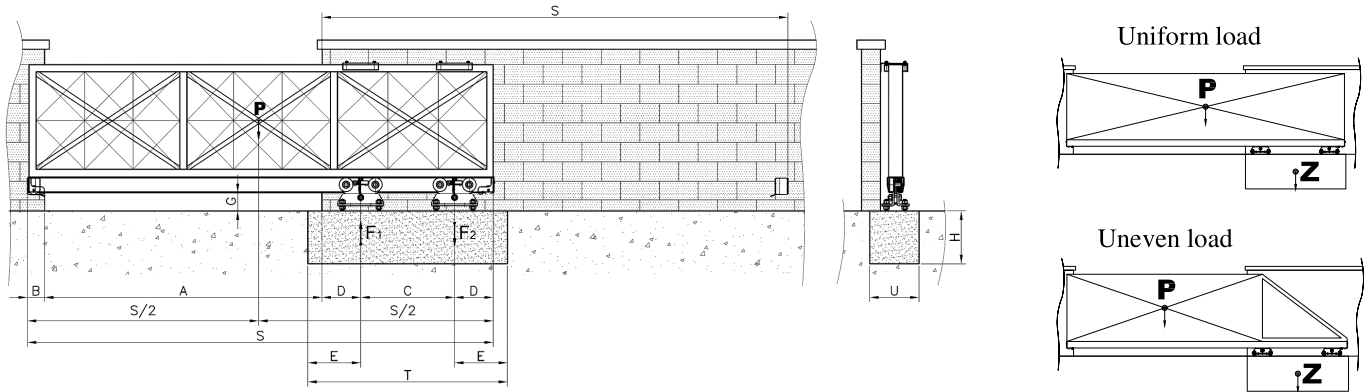

800 Series gate opening up to 5m.-Max gate weight: 300kg

A [m]	C [m]	S [m]	P max CUn[kg]	Zmin CUn[kg]	P max NUn[kg]	Zmin NUn[kg]	P Telaio [kgxML]	T [m]	U [m]	H [m]
2	0,8	3,1	300	560	220	730	85	1,3	0,4	0,5
2,5	1	3,8	300	560	220	730	70	1,5	0,4	0,5
3	1,2	4,5	300	560	220	730	60	1,7	0,4	0,5
3,5	1,4	5,2	300	560	220	730	50	1,9	0,4	0,5
4	1,6	5,9	300	560	220	730	45	2,1	0,4	0,5
4,5	1,8	6,5	300	560	220	730	40	2,3	0,4	0,5
5	2	7,3	300	560	220	730	36	2,5	0,4	0,5

Constant Data:
F1 max(kg):500
D (m):0,115
B (m):0,07
G min (m):0,05
E min (m):0,25
A/C=2,5

900S Series gate opening up to 7m.-Max gate weight: 450kg

A [m]	C [m]	S [m]	P max CUn[kg]	Zmin CUn[kg]	P max NUn[kg]	Zmin NUn[kg]	P Telaio [kgxML]	T [m]	U [m]	H [m]
3	1,2	4,7	450	900	350	1200	85	1,8	0,5	0,5
4	1,6	6,1	450	900	350	1200	65	2,2	0,5	0,5
5	2	7,5	450	900	350	1200	50	2,6	0,5	0,5
6	2,4	8,9	450	900	350	1200	42	3,0	0,5	0,5
7	2,8	10,3	450	900	350	1200	38	3,4	0,5	0,5

Constant Data:
F1 max(kg):800
D (m):0,195
B (m):0,110
G min (m):0,06
E min (m):0,30
A/C=2,5

1000S Series gate opening up to 10m.-Max gate weight: 800kg

A [m]	C [m]	S [m]	P max CUn[kg]	Zmin CUn[kg]	P max NUn[kg]	Zmin NUn[kg]	P Telaio [kgxML]	T [m]	U [m]	H [m]
4	1,6	6,2	800	1500	600	2000	115	2,3	0,6	0,6
5	2	7,6	800	1500	600	2000	95	2,7	0,6	0,6
6	2,4	9	800	1500	600	2000	80	3,1	0,6	0,6
8	3,2	11,8	800	1500	600	2000	55	3,9	0,6	0,6
10	4	14,6	800	1500	600	2000	43	4,7	0,6	0,6

Constant Data:
F1 max(kg):1000
D (m):0,260
B (m):0,115
G min (m):0,08
E min (m):0,35
A/C=2,5

2000S Series gate opening up to 14m.-Max gate weight: 1200kg

A [m]	C [m]	S [m]	P max CUn[kg]	Zmin CUn[kg]	P max NUn[kg]	Zmin NUn[kg]	P Telaio [kgxML]	T [m]	U [m]	H [m]
7	2,8	10,5	1200	2300	900	3000	95	3,7	0,8	0,6
8	3,2	11,9	1200	2300	900	3000	85	4,1	0,8	0,6
10	4	14,7	1200	2300	900	3000	65	4,9	0,8	0,6
12	4,8	17,5	1200	2300	900	3000	50	5,7	0,8	0,6
14	5,6	20,3	1200	2300	900	3000	48	6,5	0,8	0,6

Constant Data:
F1 max(kg):2000
D (m):0,290
B (m):0,115
G min (m):0,08
E min (m):0,45
A/C=2,5

3000L Series gate opening up to 18m.-Max gate weight: 1800kg

A [m]	C [m]	S [m]	P max CUn[kg]	Zmin CUn[kg]	P max NUn[kg]	Zmin NUn[kg]	P Telaio [kgxML]	T [m]	U [m]	H [m]
10	4	15	1800	3700	1400	4700	90	5,2	1	0,8
12	4,8	17,8	1800	3700	1400	4700	72	6	1	0,8
14	5,6	20,6	1800	3700	1400	4700	58	6,8	1	0,8
16	6,4	23,5	1800	3700	1400	4700	48	7,6	1	0,8
18	7,2	26,3	1800	3700	1400	4700	42	8,4	1	0,8

Constant Data:
F1 max(kg):3200
D (m):0,460
B (m):0,155
G min (m):0,10
E min (m):0,60
A/C=2,5

- A** Gate clearance .
- B** Length required to position the end stop.
- C** Distance between the trolleys.
- D** Length required to house the guide rollers.
- F1 max** Maximum acting load for trolleys best performance.
- G min** Minimum gate height.
- P max CUn** Total gate height (including all accessories) considering a uniform load.
- P max NUn** Total gate weight (including all accessories) considering an uneven load.
- P Telaio** Total liner weight per meter not considering FAC accessories (note: considering side S with a uniform load and side A with uneven load).
- S** Total gate length.
- Z1min CUn** Minimum basement weight for uniform gate load
- Z2min NUn** Minimum basement weight for gate uneven load
- TxUxH** Suggested cement dimensions.

Formulas Used

$$F1 = F2 + P$$

$$S_{min} = A + C + B + 2 \times D$$

$$Z_{min} = 2,5 \times F2$$

$$Z = 2000 \times T \times U \times H \text{ (m}^3\text{)}$$

$$F2 = \frac{P \times (A/2 + D)}{C}$$

$$C_{min} = \frac{P \times (A/2 + D)}{F1_{max} - P}$$

$$P_{max} = \frac{C \times F1_{max}}{C + D + A/2}$$



Attention: installations that do not comply with the illustrated procedure or failure to carry out correct maintenance operations can cause the gate to derail and endanger the safety of persons and propriety

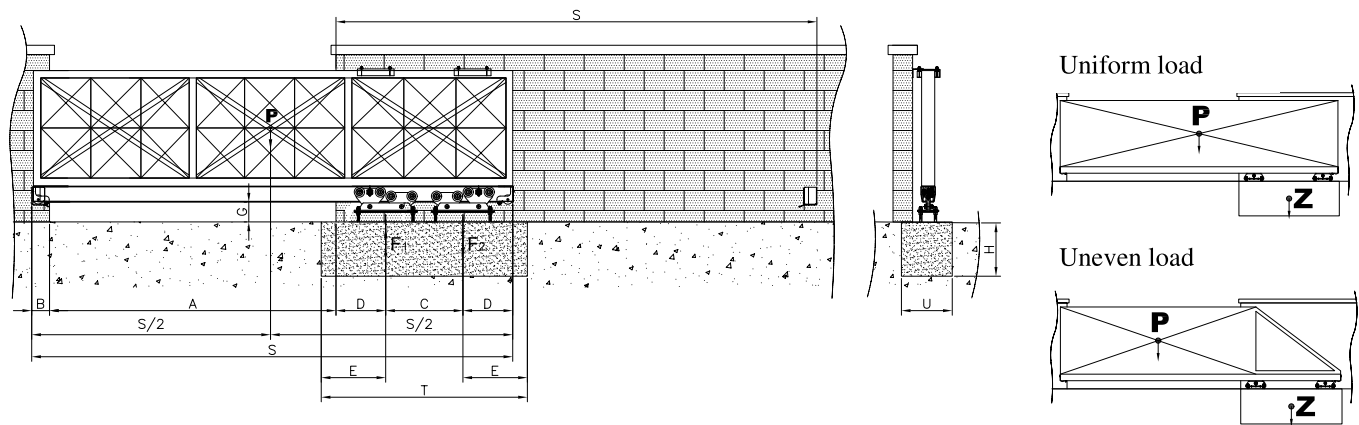

3000 Series gate opening up to 18m.-Max gate weight: 1800kg

A [m]	C [m]	S [m]	P max CUn[kg]	Zmin CUn[kg]	P max NUn[kg]	Zmin NUn[kg]	P Telaio [kgxML]	T [m]	U [m]	H [m]
10	4	15	1800	3700	1400	4700	90	5,2	1	0,8
12	4,8	17,8	1800	3700	1400	4700	72	6	1	0,8
14	5,6	20,6	1800	3700	1400	4700	58	6,8	1	0,8
16	6,4	23,5	1800	3700	1400	4700	48	7,6	1	0,8
18	7,2	26,3	1800	3700	1400	4700	42	8,4	1	0,8

Constant Data:
F1 max(kg):3200
D (m):0,309
B (m):0,155
G min (m):0,10
E min (m):0,60
A/C=2,5

2000H Series gate opening up to 20m.-Max gate weight: 2500kg

A [m]	C [m]	S [m]	P max CUn[kg]	Zmin CUn[kg]	P max NUn[kg]	Zmin NUn[kg]	P Telaio [kgxML]	T [m]	U [m]	H [m]
8	2,945	12	2300	5000	1600	6000	175	4,2	1	0,8
10	3,945	15	2300	5000	1600	6000	137	5,2	1	0,8
12	4,945	18	2350	5000	1650	6000	114	6,2	1	0,8
14	5,945	21	2350	5000	1650	6000	96	7,2	1	0,8
16	6,945	24	2400	5000	1700	6000	84	8,2	1	0,8
18	7,945	27	2450	5000	1750	6000	75	9,2	1	0,8
20	8,945	30	2500	5000	1750	6000	65	10,2	1	0,8

Constant Data:
F1 max(kg):4000
D (m):0,435
B (m):0,155
G min (m):0,12
E min (m):0,60
S=1,5xA

3000H Series gate opening up to 25m.-Max gate weight: 4000kg

A [m]	C [m]	S [m]	P max CUn[kg]	Zmin CUn[kg]	P max NUn[kg]	Zmin NUn[kg]	P Telaio [kgxML]	T [m]	U [m]	H [m]
8	2,545	12	3150	8700	2200	10.100	233	4,2	1,2	1
10	3,545	15	3200	8700	2250	10.100	184	5,2	1,2	1
12	4,545	18	3300	8700	2400	10.100	154	6,2	1,2	1
14	5,545	21	3400	8700	2450	10.100	132	7,2	1,2	1
16	6,545	24	3500	8700	2550	10.100	116	8,2	1,2	1
18	7,545	27	3600	8700	2650	10.100	104	9,2	1,2	1
20	8,545	30	3700	8700	2750	10.100	94	10,2	1,2	1
22	9,545	33	3800	8700	2800	10.100	86	11,2	1,2	1
24	10,545	36	3900	8700	2900	10.100	79	12,2	1,2	1
25	11,045	37,5	4000	8700	3000	10.100	77	13,2	1,2	1

Constant Data:
F1 max(kg):6400
D (m):0,65
B (m):0,155
G min (m):0,15
E min (m):0,8
S=1,5xA

- A** Gate clearance .
- B** Length required to position the end stop
- C** Distance between the trolleys
- D** Length required to house the guide rollers.
- F1 max** Maximum acting load for trolleys best performance.
- G min** Minimum gate height.
- P max CUn** Total gate height (including all accessories) considering an uniform load.
- P max NUn** Total gate weight (including all accessories) considering an uneven load.
- P Telaio** Total liner weight per meter not considering FAC accessories (note: considering side S with an uniform load and side A with uneven load.
- S** Total gate length.
- Z1min CUn** Minimum basement weight for uniform gate load
- Z2min NUn** Minimum basement weight for gate uneven load
- TxUxH** Suggested cement dimensions.

Formulas Used:

$$F1 = F2 + P$$

$$S_{min} = A + C + B + 2 \times D$$

$$Z_{min} = 2,5 \times F_2$$

$$Z = 2000 \times T \times U \times H \text{ (m}^3\text{)}$$



Attention: installations that do not comply with the illustrated procedure or failure to carry out correct maintenance operations can cause the gate to derail and endanger the safety of persons and propriety

Recommended installation instructions for Cantilever Systems

1. Set the dimension C as the maximum possible with the available spaces, not as the minimum for the load in question, and try not to exceed the value 3 of the A/C. The ideal $C = A/3$. This will assure the best gate working condition during gate movement.

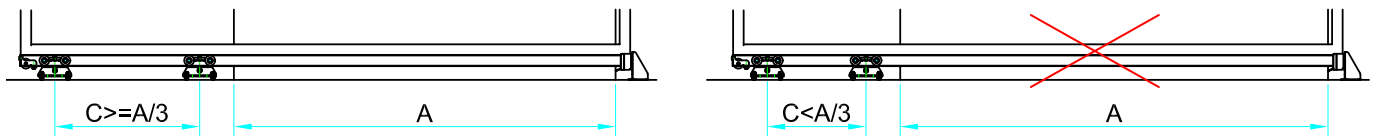

2. Comply with the D value between the carriages, this value will optimize the spaces and loads.

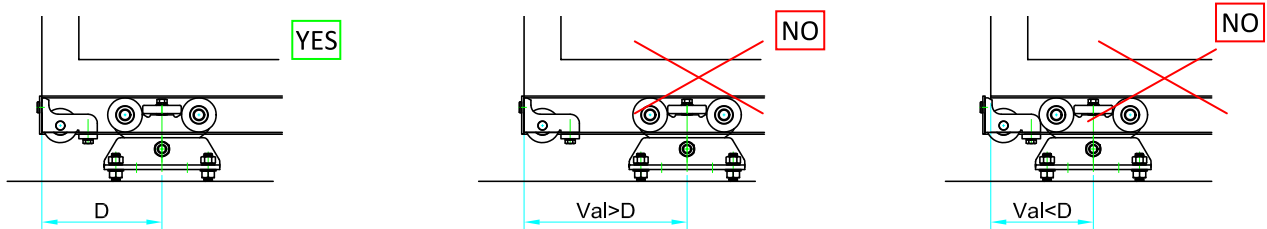

3. Fix the trolleys on the ground so that they are firmly supported in correspondence of the fixing rods, the trolleys must be aligned along the sliding axis of the gate and make sure the bases are perfectly horizontal, this will ensure that all wheels will work simultaneously and turn without dragging on the rail.

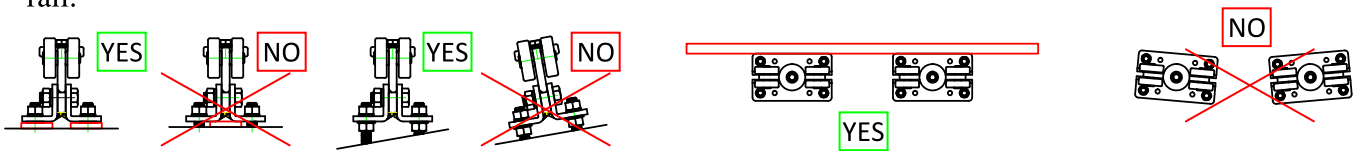

4. Make sure the rocker arm is not locked and can move freely on its pivot point, this will allow the wheels to adapt to any irregularities of the rail during gate movement.

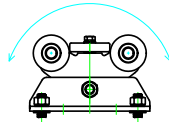

5. The gate must be positioned vertically above the carriages and the rail must be firmly fixed and the sliding surfaces of the wheels must be perfectly horizontal, this will ensure the maximum weight and radial force distribution on all wheels.

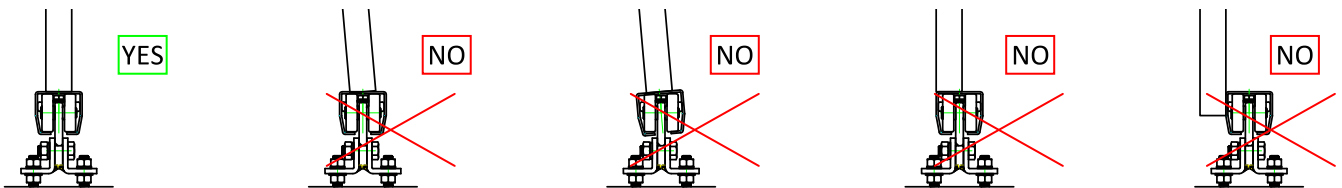

6. Always use an end stop and a guide roller, if not possible make sure the gate comes to rest in some way. This will prevent gate wobbling and will help relief some of its load when the gate is fully opened or fully closed;



Attention: installations that do not comply with the illustrated procedure or failure to carry out correct maintenance operations can cause the gate to derail and endanger the safety of persons and property

7. Fix the upper guide directly in contact with the gate frame this will eliminate all possible slack and wobbling of the gate during movement.

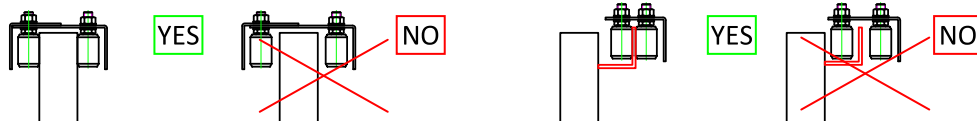

8. Once installed, slide the gate by hand and make sure that there are no rubbing of any kind or fluctuations, if needed perform all required adjustments.
9. Ensure sufficient rigidity in order to prevent and gate bending (especially in very long gates). It is advisable to adopt one of the following methods:

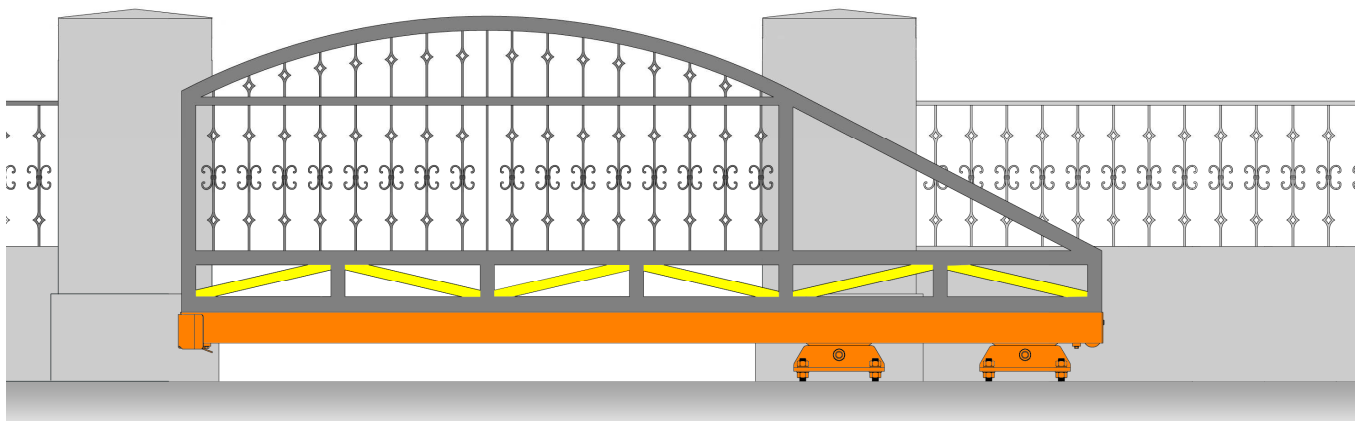
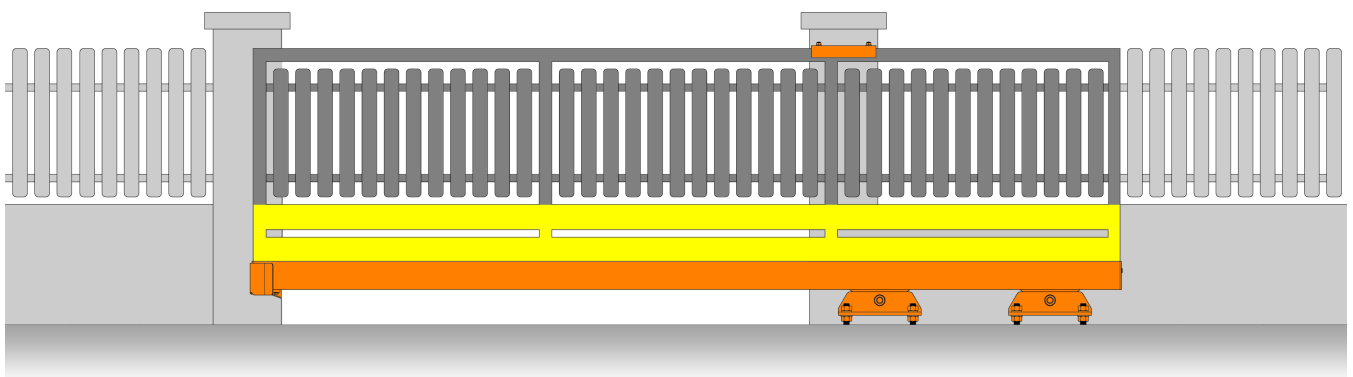
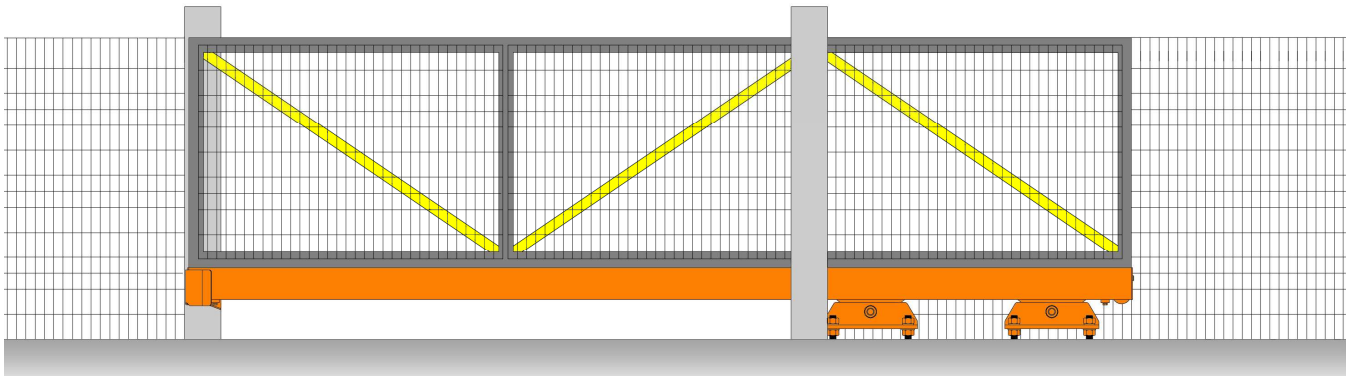

Maintenance

To maintain these articles in efficient and safe conditions it is sufficient to follow this check list:

1. After assembly run a few manual opening and closing cycles and check for loose parts. Periodically check for slacks.
2. In case of accidents or impacts, check and make sure the trolleys, the rail and any part used to assure the movement of the gate have not been hit or damaged. The hardware should never be compromised in order to assure the functionality of the gate. If necessary, replace all damaged parts.
3. In case the wheels start having difficulty turning or start fluctuating it is an indication of worn bearings. Replace them when necessary. Working conditions with high humidity, salt, acids, dusty or with temperatures higher than 120 ° C considerably reduces the life cycle of the bearings.



Attention: installations that do not comply with the illustrated procedure or failure to carry out correct maintenance operations can cause the gate to derail and endanger the safety of persons and property