

## BI-FOLDING GATE KIT

### Description

All items contained in the kit are made of galvanized steel and are specially designed swing gate bi-folding applications. The gates on which the kit is used can be motorized. The system allows for the gate folding parts to move simultaneously. Bifolding gate takes limited space when open.

<b>Family of parts</b>
KC7101

SCAN FOR MORE INFO

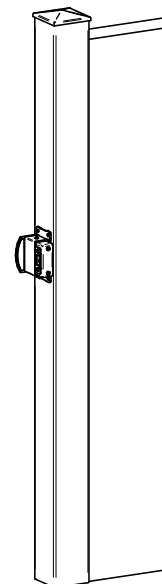
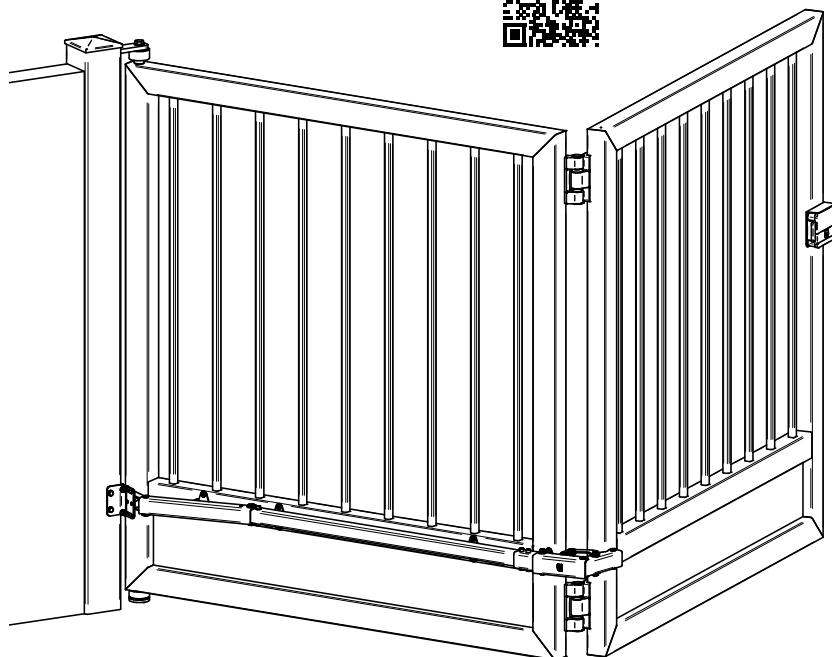

### Component list

1x	1x	2x
<b>Profilo C-C Profile</b> 40x40x2 Optional VA5401.003/006	<b>Carter Protezione</b> Protective cover VC7105.060	VC4111.B50 – VC4171.B40/50 <b>Recommended</b>
		VC4202.050-VC4261.040-VC4262.050 VC4212.B50-VC4271.B40-VC4272.B50 <b>Recommended</b>

# Install Kit on the leaf before the gate is erected (Pictures. 1-10)

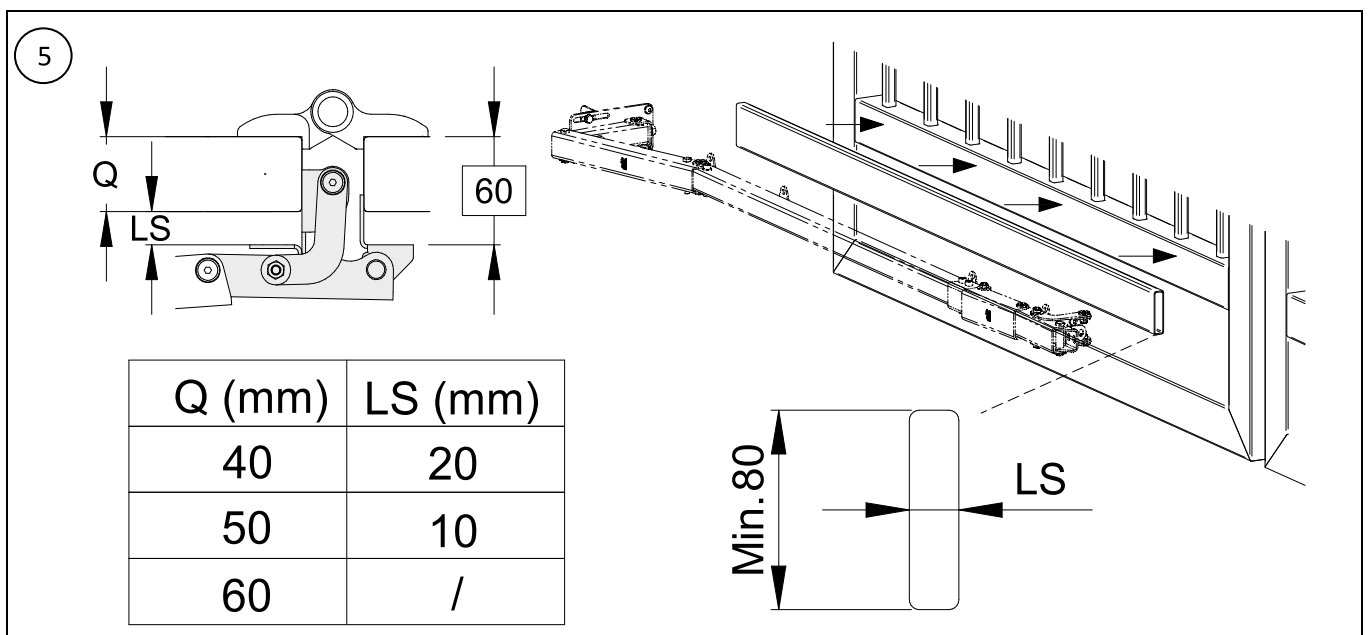
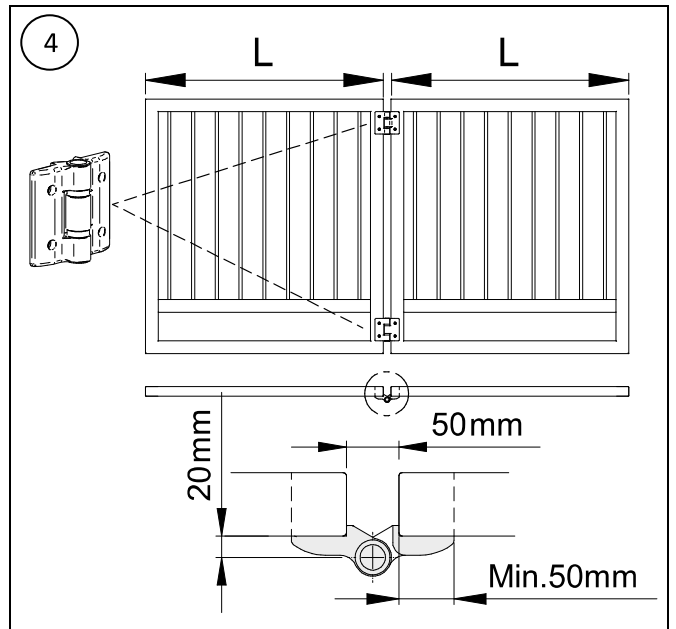
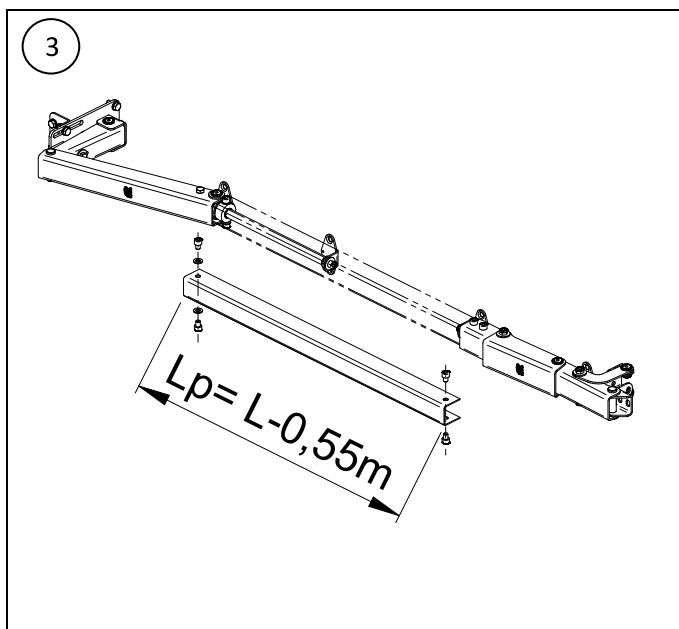
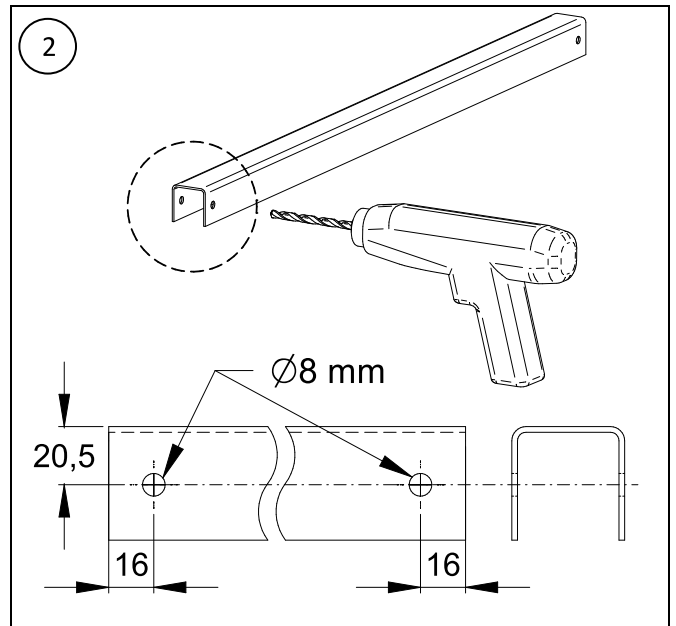
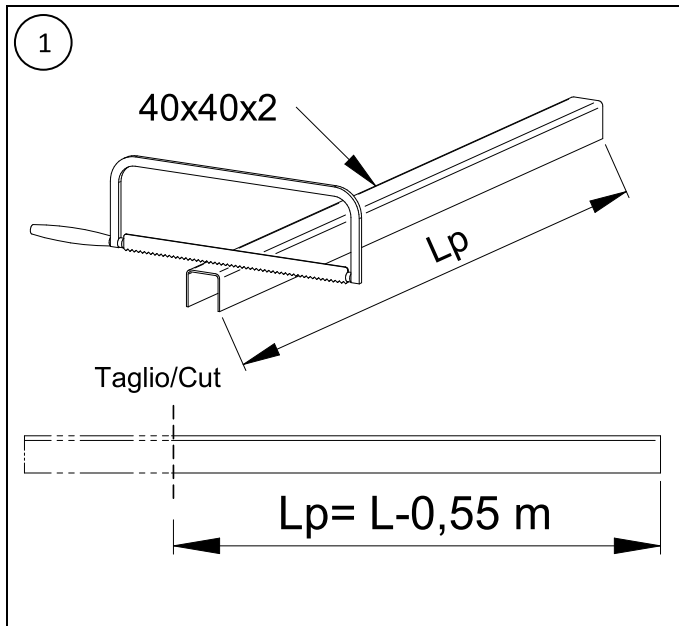

**Attention:** installations that do not comply with the illustrated procedure or failure to carry out correct maintenance operations can cause the gate to fail and endanger the safety of persons and propriety

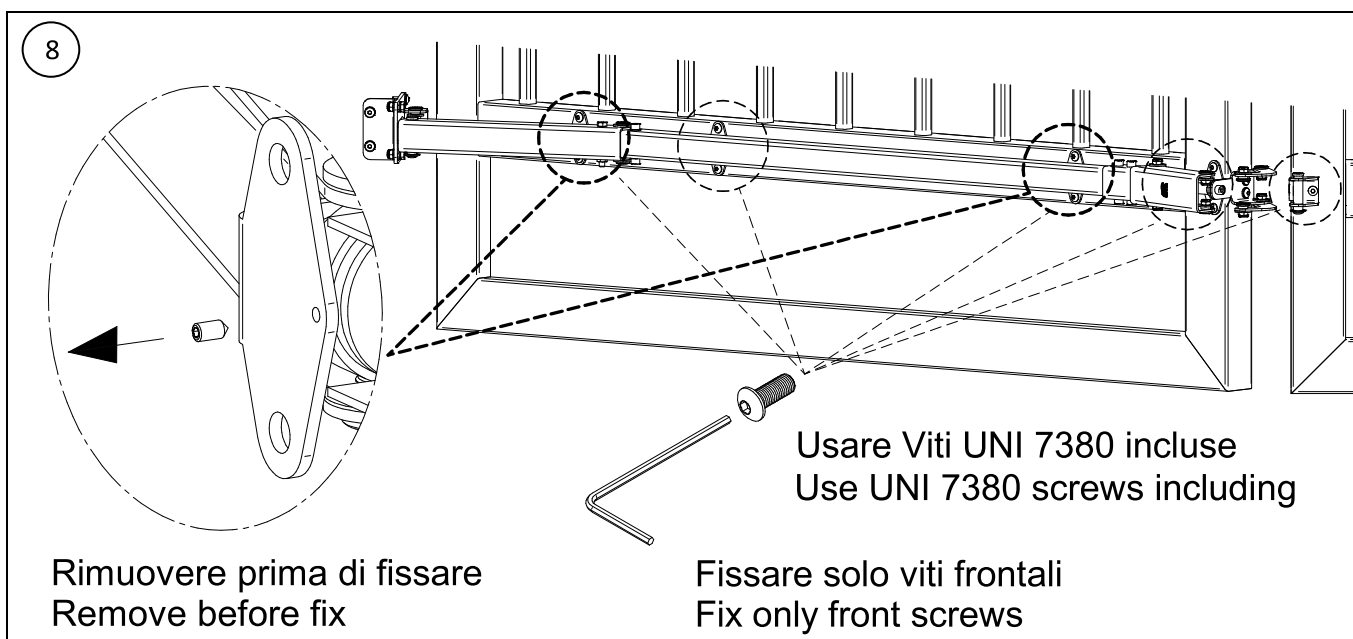
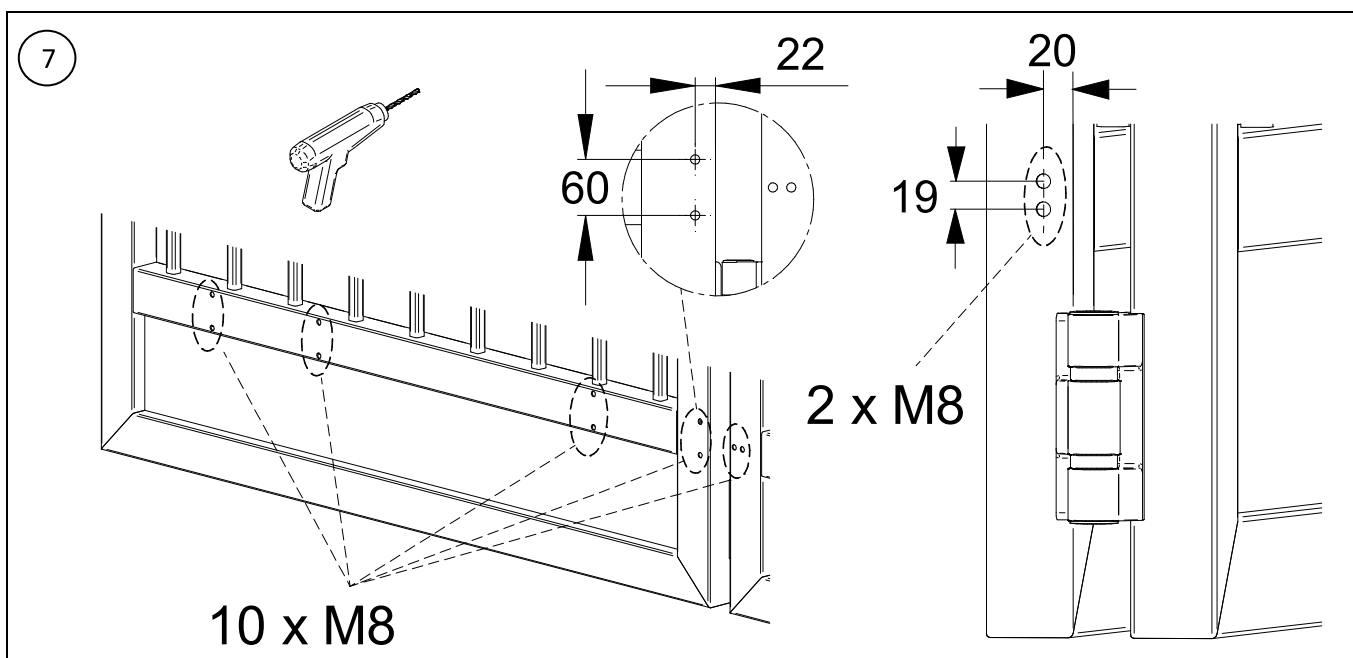
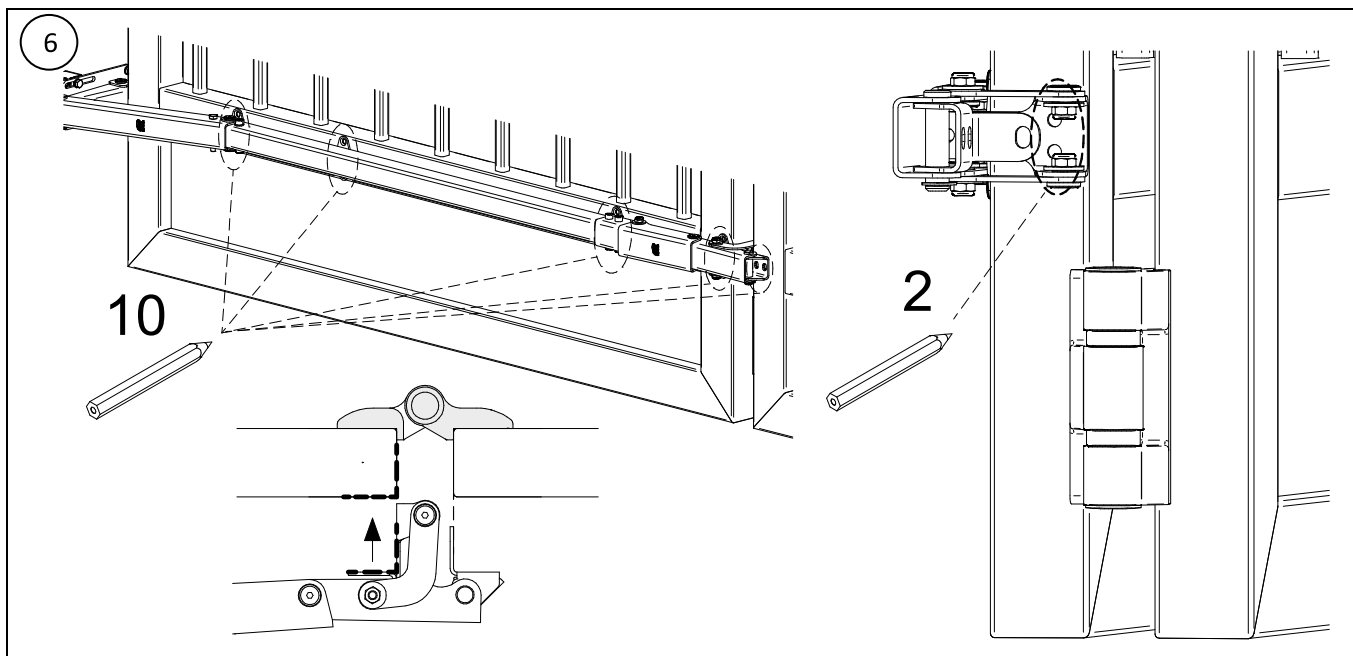

**Attention:** installations that do not comply with the illustrated procedure or failure to carry out correct maintenance operations can cause the gate to fail and endanger the safety of persons and property

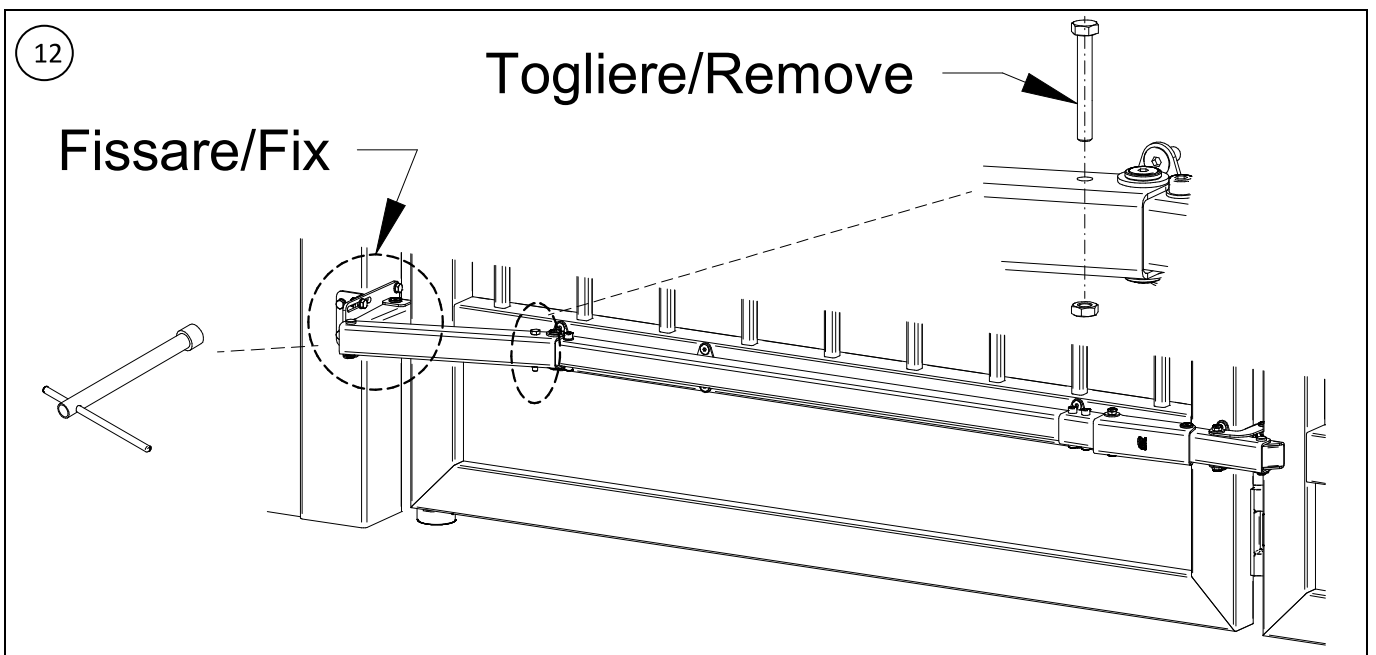
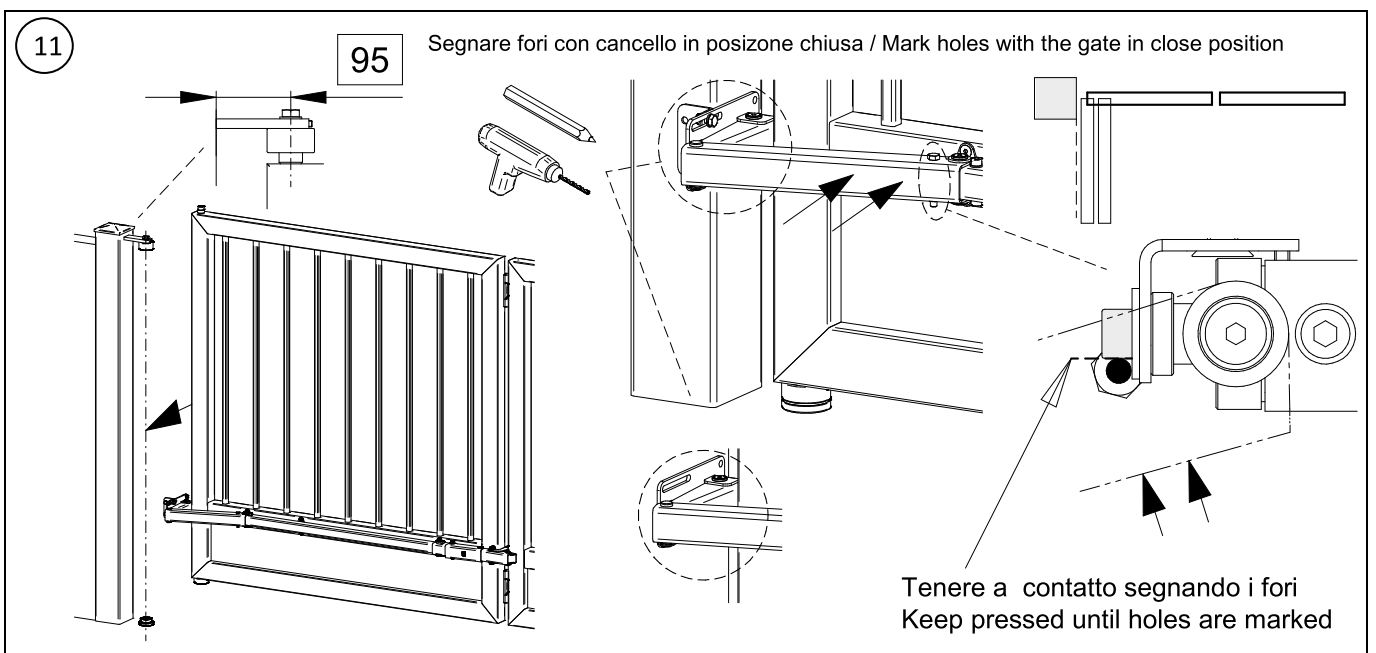
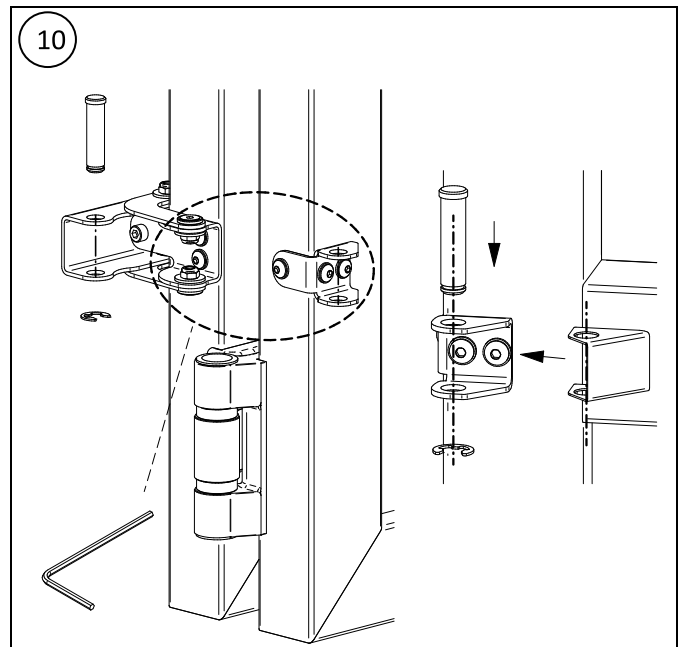
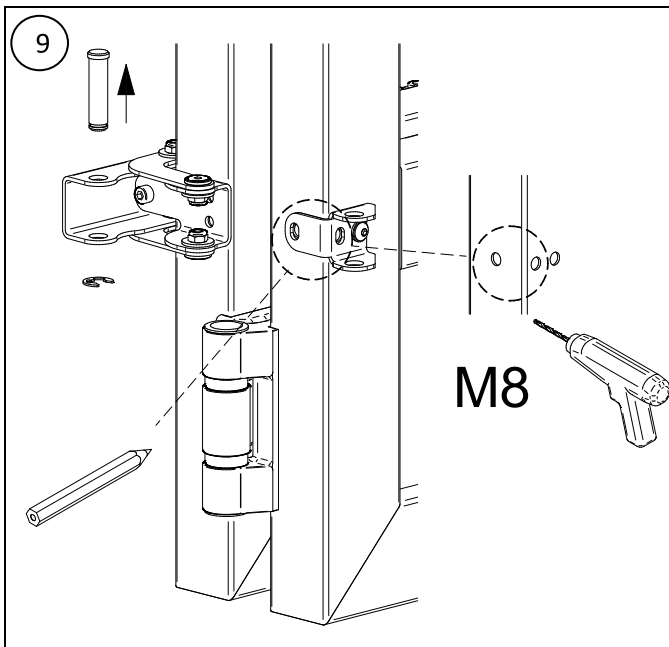

**Attention:** installations that do not comply with the illustrated procedure or failure to carry out correct maintenance operations can cause the gate to fail and endanger the safety of persons and property

13

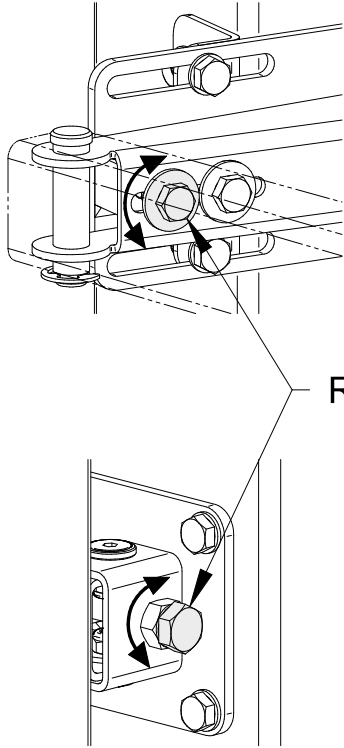

Registrazione/Adjustment

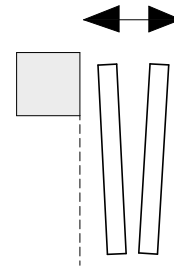

14

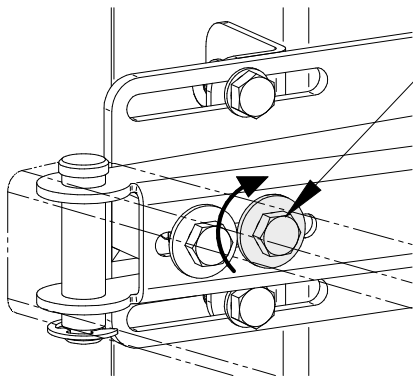

Fissaggio/Fixing

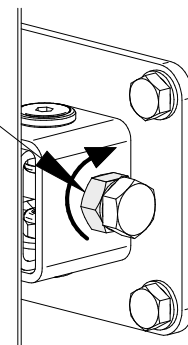

15

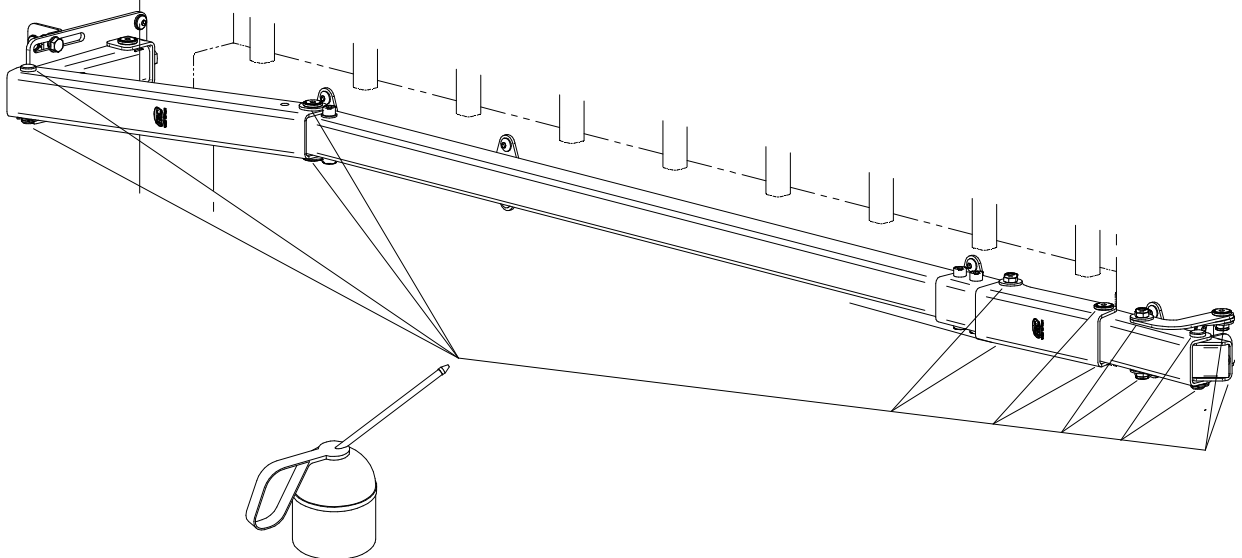

**Attention:** installations that do not comply with the illustrated procedure or failure to carry out correct maintenance operations can cause the gate to fail and endanger the safety of persons and property

## DIMENSIONING TABLE

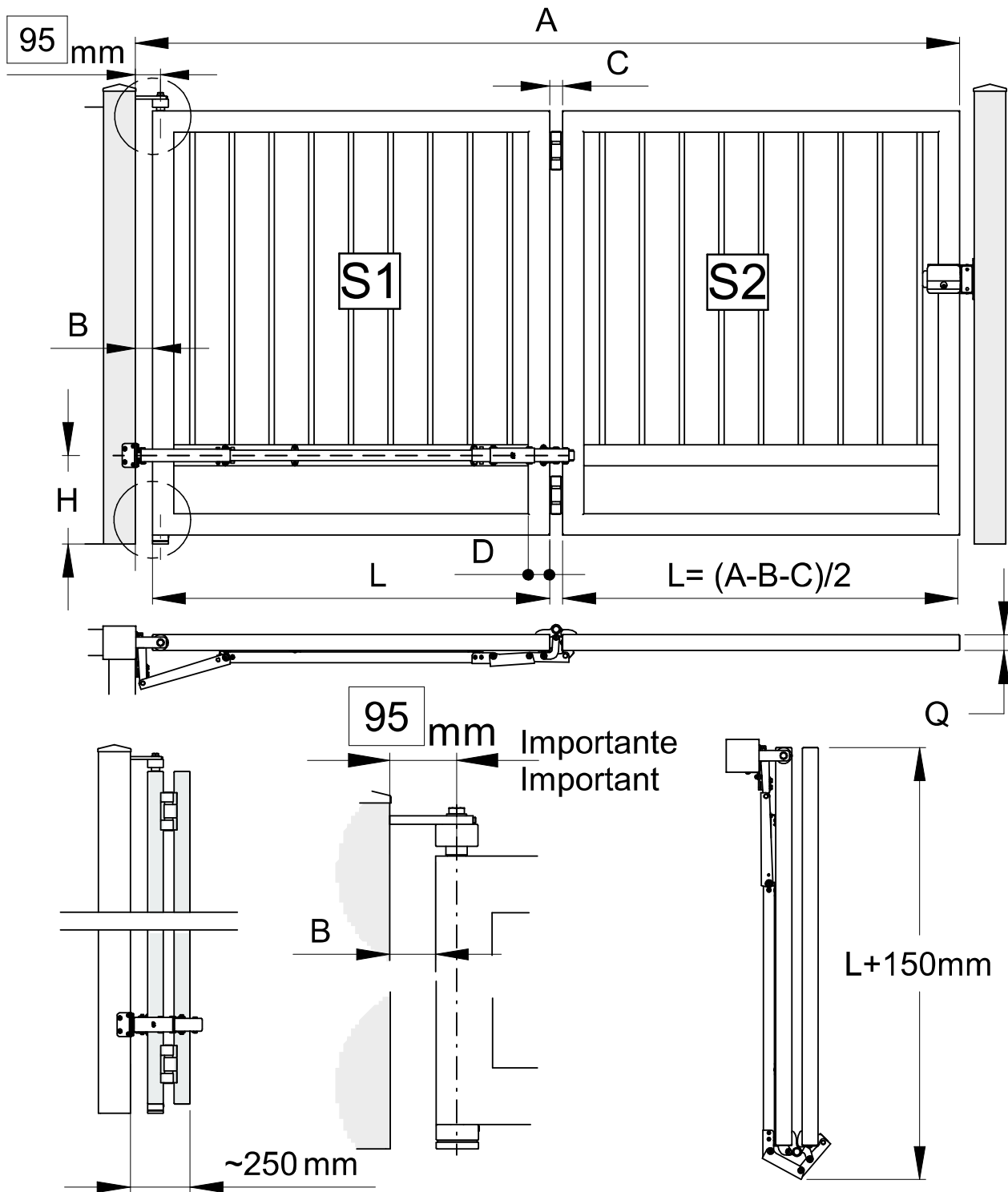

### DIMENSION TABLE

A min-max [m]	B min [mm]	C [mm]	D [mm]	H	L min [m]	Q [mm]
1,9 - 5	65	50	Min.50	Near the engine	0,89	40-50-60



**Attention:** installations that do not comply with the illustrated procedure or failure to carry out correct maintenance operations can cause the gate to fail and endanger the safety of persons and property

A[m]	L [m] with B=0,07	Max weight S2 [Kg]
2	0,94	205
2,5	1,19	170
3	1,44	145
3,5	1,69	120
4	1,94	105
4,5	2,19	95
5	2,44	85

#### Example dimensions not in table

A=2,8m

B=0,07m (min 0,065 m)

C=0,05m (da tabella sopra/from above table)

$$L=(A-B-C)/2$$

$$L=(2,8-0,07-0,05)/2$$

$$L=2,68/2$$

$$L=1.34 \text{ m}$$

### Max S2 leaf weight according to the L lenght

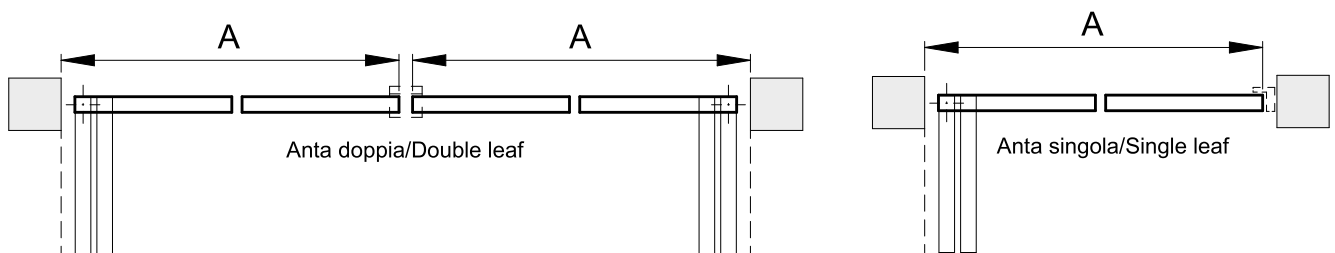
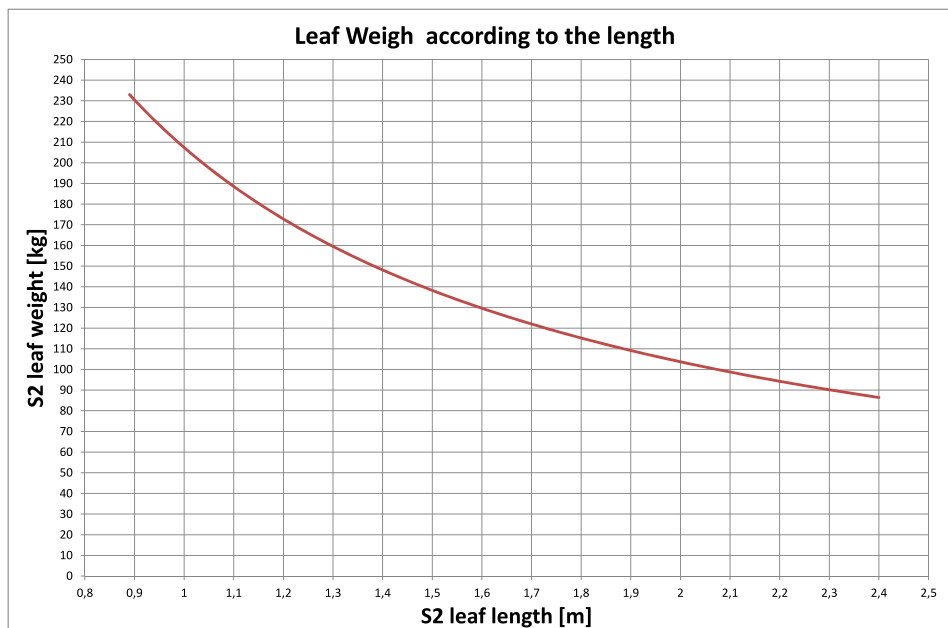

**Important:** If motorized set soft starts and stops to avoid elastic effects between the leaves

### Maintenance

To maintain these parts in good and safe working conditions it is necessary to follow these steps:

1. After gate assembly is completed, perform a few manual opening and closing cycles, make sure there are no loose parts and periodically lubricate all bearings and junction points.
2. In case of accidental shock caused by moving vehicles or other external factors, check parts for external damages. In case of irreparable damage, replace with a new part. Always check the gate by manually opening a few opening and closing cycles. All maintenance procedures must be performed by trained technicians.
3. If the gate has any difficulty of movement or in presence of abnormal oscillations, the gate must be checked for worn parts and must be replaced if necessary. Gates working in harsh ambient conditions, such as; high humidity, salt, acids, dust or temperatures above 120°C will require special attention and frequent maintenance.
4. For motorized gates, pay special attention when selecting the operational speed. Soft starts and stops are highly recommended:
  - High speed of operation, and hard starts and stops may result in loosen nuts, bolts and irreparable damage.



**Attention:** installations that do not comply with the illustred procedure or failure to carry out correct maintenance operations can cause the gate to fail and endanger the safety of persons and propriety